

# CMS EMU Muon Port Card MPC2004 Production Version Specification

Rice University

10/08/2008

## Introduction

In each of stations 2-4 of the Cathode Strip Chambers (CSC) at the CMS Experiment, the Muon Port Card (MPC2004) receives up to two trigger primitives (called Local Charged Tracks, or LCT) from nine chambers corresponding to 60 degree sectors, or 18 in total. The MPC2004 reduces the number of LCTs to three and sends them via optical links to the Sector Processors (SP) [1] residing in the Track Finder (TF) crate. In station 1, it receives LCT's from eight chambers corresponding to 20 degree sectors. The MPC2004 resides in the middle of the 21-slot 9U crate that is located on the periphery of the return yoke of the CMS detector. Other slots in a crate are occupied with the Trigger Motherboards (TMB) [2], DAQ Motherboards [3], Clock and Control Board (CCB) [4] and the VME controller. A block diagram of the MPC2004 board is shown on Figure 1.

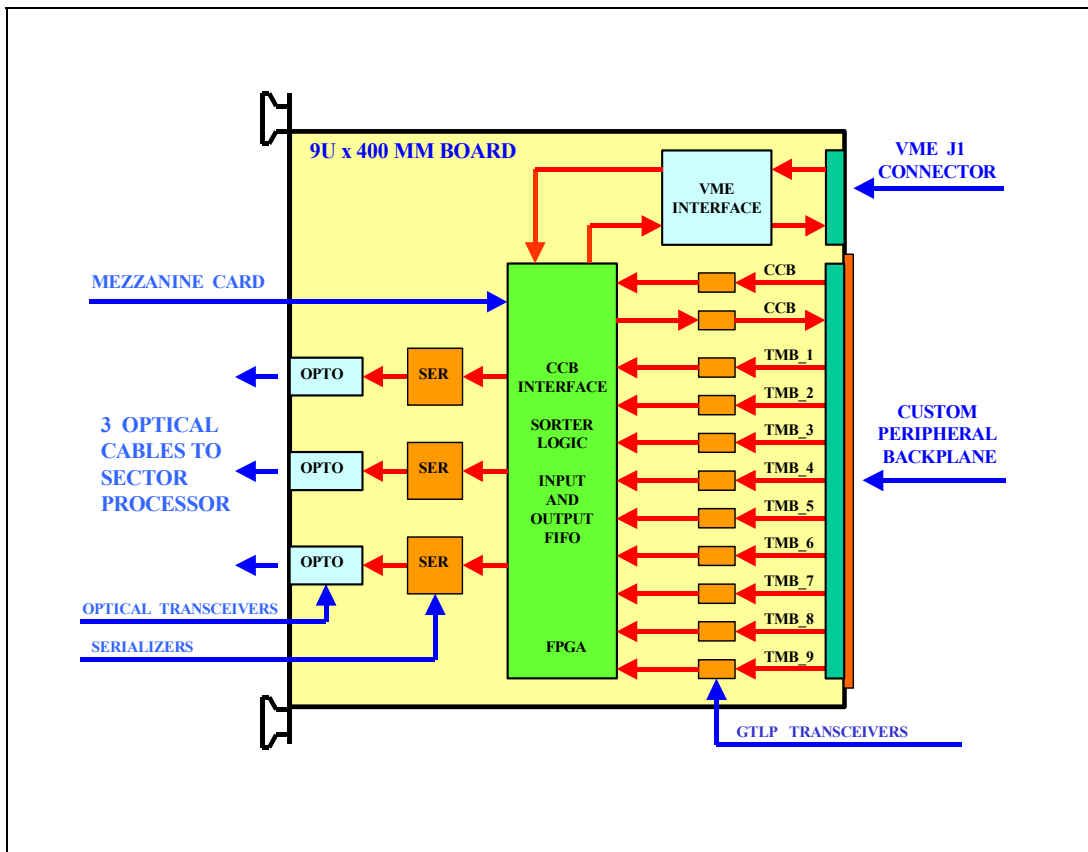

Figure 1: Block Diagram of the Muon Port Card

## 1. Interface to Clock and Control Board

The CCB distributes several common (bussed) and individual (point-to-point) signals to each module in the peripheral crate. A full list of these signals is given in the CCB manual [4]. Its subset relevant to the MPC2004 is shown in Table 1. Two clock signals, 40.08MHz and 80.16MHz, are distributed from the CCB over LVDS lines. All the rest signals are transmitted using the GTLP logic standard, with active level “0”. The list of commands decoded by the MPC2004 is shown in Table 2.

Table 1

CCB-to-MPC Signals

Signal	Bits	Type	Logic	Duration
Ccb_clk40	1	Point-to-point	LVDS	40.08Mhz
Clk80_MPC	1	Point-to-point	LVDS	80.16Mhz
Fast Control Bus				
Ccb_clock40_enable	1	Bussed	GTLP	40.08Mhz
Ccb_cmd[5..0]	6	Bussed	GTLP	Level
Ccb_evtres	1	Bussed	GTLP	25 ns
Ccb_bcntres	1	Bussed	GTLP	25 ns
Ccb_cmd_strobe	1	Bussed	GTLP	25 ns
Ccb_bc0	1	Bussed	GTLP	25 ns
Ccb_llaccept	1	Bussed	GTLP	25 ns
Ccb_data[7..0]	8	Bussed	GTLP	Level
Ccb_data_strobe	1	Bussed	GTLP	25 ns
Ccb_ttrrx_ready (former ccb_reserved[0])	1	Bussed	GTLP	Level
QPLL_locked (former ccb_reserved[1])	1	Bussed	GTLP	Level
Ccb_L1Reset (former ccb_reserved[4])	1	Bussed	GTLP	25 ns
Ccb_reserved[3..2]	2	Bussed	GTLP	Level
Total	26			
MPC Reload Bus				
Mpc_hard_reset	1	Point-to-point	GTLP	300 ns
Mpc_cfg_done	1	Point-to-point	GTLP	Level
Mpc_soft_reset (former Mpc_reserved[2])	1	Point-to-point	GTLP	25 ns
Mpc_reserved[1..0]	2	Point-to-point	GTLP	25 ns
Total	5			

Table 2

Commands decoded from the ccb\_cmd[5..0] lines

Command	Ccb_cmd[5..0] code (hex)	Action
L1Reset	3	Generates a 3.2 us negative pulse on TX_EN pin of TLK2501 transmitters (IDLE mode)
Hard Reset	4	Reload XCV600E FPGA from the EPROM
MPC Hard Reset	13	Reload XCV600E FPGA from the EPROM
Soft Reset	1C	Reset FIFO_A and FIFO_B
MPC Soft Reset	1F	Reset FIFO_A and FIFO_B
Inject patterns from MPC	30	Send test patterns from the MPC FIFO_A to the SP

## 2. Sorter Unit and Interface to Trigger Motherboard

The TMB can send to MPC2004 up to two LCTs every 25 ns. Each LCT is represented by 32 bits that are sent in two frames at 80 MHz. The frame format is shown in Table 3. The “old” signal names in the second column are referred to initial document [5]. Pin assignment of the custom backplane connectors is shown in Tables 4-7. Any individual LCT (from any TMB or from any FIFO\_A) can be masked out using CSR7 and CSR8

(see Section 7). When disabled, it is ignored by the sorting unit of the Port Card. By default (after power cycling) CSR7=CSR8="0" (all bits), so all the LCT's are enabled.

The MPC2004 sorting unit accepts 18 4-bit patterns "Quality[3..0]" that represent the "quality" of each incoming LCT and produces the three best (having the largest value of the "quality") patterns in ranked order. LCTs with "Quality"=0 and "vpf"=0 are cancelled by the sorter unit. Depending on firmware revision (see details at <http://bonner-ntserver.rice.edu/cms/projects.html#mpc>), LCTs with "Quality=0" and "vpf=1" may or may not participate in sorting. If several patterns happen to have the same valid "Quality" value, then the pattern arriving from the TMB with the largest slot number in the crate will have the precedence. If two LCT from the same TMB are selected and both have the same "quality" value, then the LCT0 will have the precedence over LCT1. Selected 32-bit patterns are multiplexed into two 16-bit frames on the FPGA outputs and sent directly to TLK2501 serializers [6] in ranked order (see Section 3).

Table 3

TMB-to-MPC data Format (i=1..9)

Line	Old Name	First frame transmitted at 80Mhz		Second frame transmitted at 80Mhz	
		Signal	LCT	Signal	LCT
TMBi[0]	Lcti vpf	Wire Group 0	0	½-strip 0	0
TMBi[1]	Lcti qual0	Wire Group 1	0	½-strip 1	0
TMBi[2]	Lcti qual1	Wire Group 2	0	½-strip 2	0
TMBi[3]	Lcti qual2	Wire Group 3	0	½-strip 3	0
TMBi[4]	Lcti qual3	Wire Group 4	0	½-strip 4	0
TMBi[5]	Lcti qual4	Wire Group 5	0	½-strip 5	0
TMBi[6]	Lcti qual5	Wire Group 6	0	½-strip 6	0
TMBi[7]	Lcti qual6	CLCT Pattern ID0	0	½-strip 7	0
TMBi[8]	Lcti qual7	CLCT Pattern ID1	0	L/R Bend Angle	0
TMBi[9]	Lcti qual8	CLCT Pattern ID2	0	SYNC ER	0
TMBi[10]	Lcti hs0	CLCT Pattern ID3	0	BXN[0]	0
TMBi[11]	Lcti hs1	Quality 0	0	BC0	0
TMBi[12]	Lcti hs2	Quality 1	0	CSC ID0	0
TMBi[13]	Lcti hs3	Quality 2	0	CSC ID1	0
TMBi[14]	Lcti hs4	Quality 3	0	CSC ID2	0
TMBi[15]	Lcti hs5	Valid Pattern Flag	0	CSC ID3	0
TMBi[16]	Lcti hs6	Wire Group 0	1	½-strip 0	1
TMBi[17]	Lcti hs7	Wire Group 1	1	½-strip 1	1
TMBi[18]	Lcti wg0	Wire Group 2	1	½-strip 2	1
TMBi[19]	Lcti wg1	Wire Group 3	1	½-strip 3	1
TMBi[20]	Lcti wg2	Wire Group 4	1	½-strip 4	1
TMBi[21]	Lcti wg3	Wire Group 5	1	½-strip 5	1
TMBi[22]	Lcti wg4	Wire Group 6	1	½-strip 6	1
TMBi[23]	Lcti wg5	CLCT Pattern ID0	1	½-strip 7	1
TMBi[24]	Lcti wg6	CLCT Pattern ID1	1	L/R Bend Angle	1
TMBi[25]	Lcti acmu	CLCT Pattern ID2	1	SYNC ER	1
TMBi[26]	Lcti bx0	CLCT Pattern ID3	1	BXN[0]	1
TMBi[27]	Lcti bx1	Quality 0	1	BC0	1
TMBi[28]	Lcti rsv0	Quality 1	1	CSC ID0	1
TMBi[29]	Lcti rsv1	Quality 2	1	CSC ID1	1
TMBi[30]	Lcti rsv2	Quality 3	1	CSC ID2	1
TMBi[31]	Lcti rsv3	Valid Pattern Flag	1	CSC ID3	1

The MPC2004 chooses the best three out of 18 patterns it receives every 25 ns. If a particular pattern is accepted by MPC2004, then a “winner” bit is sent from MPC2004 back to corresponding TMB. The total number of “winner” bits is 18, and they are sent back to TMB’s in two 80Mhz frames. The “1” in the first frame indicates that an LCT0 from the particular TMB was accepted. The “1” in the second frame indicates that the LCT1 from a given TMB was accepted.

The input clock on MPC2004 board must be adjusted in respect to master CCB clock for reliable latching of 80Mhz data streams from all nine TMB boards into the FPGA. It can be done with CSR2[15..8] bits when CSR0[13]=0. During initial tests of the EMU peripheral crate in October 2005 it was found that for nine TMB2005 boards the “safe window” of data latching is when the CSR2[15..8]=(25...3B)h, or 5.5 ns. If CSR0[13]=1, then the clock will be set to a predefined value precisely in the middle of the “safe window” (which corresponds to CSR2[15..8]=30h). In this case there is no need to program the CSR2.

All signals from nine TMB’s (32\*9=288 lines) to MPC2004 as well as “winner” bits are transmitted over point-to-point lines using “negative” (active “0”) GTLP logic. They are terminated (56 Ohm to +1.5V) on the MPC2004 board. Pin assignment for all four backplane connectors at the MPC slot 12 is given in Tables 4..7 (signal names and connector numbers are referred to [5]). Two sources of +1.5V power (Tables 6-7) from the custom backplane are used for GTLP termination only.

Table 4

Pin assignment of the P1 backplane connector (top)

Pin	Signal	Pin	Signal	Pin	Signal	Pin	Signal	Pin	Signal
A1	Ccb_clk40+	B1	Ccb_clk40-	C1	GND	D1	Mpc_hreset	E1	Mpc_rsv_0
A2		B2		C2	GND	D2	Mpc_rsv_1	E2	Mpc_rsv_2
A3		B3		C3	GND	D3		E3	Mpc_cfg_d
A4		B4		C4	GND	D4	Clk80_mpc+	E4	Clk80_mpc-
A5	Clk enable	B5	Ccb_rsv_4	C5	GND	D5		E5	
A6	Cem_cmd_0	B6	Ccb_cmd_1	C6	GND	D6	Ccb_cmd_2	E6	Ccb_cmd_3
A7	Ccb_cmd_4	B7	Ccb_cmd_5	C7	GND	D7	Ccb_evtres	E7	Ccb_bntres
A8	Ccb_cmd_str	B8	Ccb_bc0	C8	GND	D8	Ccb_11a	E8	Ccb_dstrobe
A9	Ccb_data_0	B9	Ccb_data_1	C9	GND	D9	Ccb_data_2	E9	Ccb_data_3
A10	Ccb_data_4	B10	Ccb_data_5	C10	GND	D10	Ccb_data_6	E10	Ccb_data_7
A11	Ccb_tterx_rd	B11	Ccb_rsv_1	C11	GND	D11	Ccb_rsv_2	E11	Ccb_rsv_3
A12	TMB8[0]	B12	TMB8[1]	C12	GND	D12	TMB8[2]	E12	TMB8[3]
A13	TMB8[4]	B13	TMB8[5]	C13	GND	D13	TMB8[6]	E13	TMB8[7]
A14	TMB8[8]	B14	TMB8[9]	C14	GND	D14	TMB8[10]	E14	TMB8[11]
A15	TMB8[12]	B15	TMB8[13]	C15	GND	D15	TMB8[14]	E15	TMB8[15]
A16	TMB8[16]	B16	TMB8[17]	C16	GND	D16	TMB8[18]	E16	TMB8[19]
A17	TMB8[20]	B17	TMB8[21]	C17	GND	D17	TMB8[22]	E17	TMB8[23]
A18	TMB8[24]	B18	TMB8[25]	C18	GND	D18	TMB8[26]	E18	TMB8[27]
A19	TMB8[28]	B19	TMB8[29]	C19	GND	D19	TMB8[30]	E19	TMB8[31]
A20	TMB2[0]	B20	TMB2[1]	C20	GND	D20	TMB2[2]	E20	TMB2[3]
A21	TMB2[4]	B21	TMB2[5]	C21	GND	D21	TMB2[6]	E21	TMB2[7]
A22	TMB2[8]	B22	TMB2[9]	C22	GND	D22	TMB2[10]	E22	TMB2[11]
A23	TMB2[12]	B23	TMB2[13]	C23	GND	D23	TMB2[14]	E23	TMB2[15]
A24	TMB2[16]	B24	TMB2[17]	C24	GND	D24	TMB2[18]	E24	TMB2[19]
A25	TMB2[20]	B25	TMB2[21]	C25	GND	D25	TMB2[22]	E25	TMB2[23]

Table 5

## Pin assignment of the P3 backplane connector (middle top)

Pin	Signal	Pin	Signal	Pin	Signal	Pin	Signal	Pin	Signal
A1	TMB2[24]	B1	TMB2[25]	C1	GND	D1	TMB2[26]	E1	TMB2[27]
A2	TMB2[28]	B2	TMB2[29]	C2	GND	D2	TMB2[30]	E2	TMB2[31]
A3	Winner_2	B3	Winner_4	C3	GND	D3	Winner_6	E3	Winner_8
A4	TMB6[0]	B4	TMB6[1]	C4	GND	D4	TMB6[2]	E4	TMB6[3]
A5	TMB6[4]	B5	TMB6[5]	C5	GND	D5	TMB6[6]	E5	TMB6[7]
A6	TMB6[8]	B6	TMB6[9]	C6	GND	D6	TMB6[10]	E6	TMB6[11]
A7	TMB6[12]	B7	TMB6[13]	C7	GND	D7	TMB6[14]	E7	TMB6[15]
A8	TMB6[16]	B8	TMB6[17]	C8	GND	D8	TMB6[18]	E8	TMB6[19]
A9	TMB6[20]	B9	TMB6[21]	C9	GND	D9	TMB6[22]	E9	TMB6[23]
A10	TMB6[24]	B10	TMB6[25]	C10	GND	D10	TMB6[26]	E10	TMB6[27]
A11	TMB6[28]	B11	TMB6[29]	C11	GND	D11	TMB6[30]	E11	TMB6[31]

Table 6

## Pin assignment of the P2 backplane connector (middle bottom)

Pin	Signal	Pin	Signal	Pin	Signal	Pin	Signal	Pin	Signal
A1	TMB4[0]	B1	TMB4[1]	C1	GND	D1	TMB4[2]	E1	TMB4[3]
A2	TMB4[4]	B2	TMB4[5]	C2	+1.5	D2	TMB4[6]	E2	TMB4[7]
A3	TMB4[8]	B3	TMB4[9]	C3	GND	D3	TMB4[10]	E3	TMB4[11]
A4	TMB4[12]	B4	TMB4[13]	C4	+1.5	D4	TMB4[14]	E4	TMB4[15]
A5	TMB4[16]	B5	TMB4[17]	C5	GND	D5	TMB4[18]	E5	TMB4[19]
A6	TMB4[20]	B6	TMB4[21]	C6	+1.5	D6	TMB4[22]	E6	TMB4[23]
A7	TMB4[24]	B7	TMB4[25]	C7	GND	D7	TMB4[26]	E7	TMB4[27]
A8	TMB4[28]	B8	TMB4[29]	C8	+1.5	D8	TMB4[30]	E8	TMB4[31]
A9	TMB5[0]	B9	TMB5[1]	C9	GND	D9	TMB5[2]	E9	TMB5[3]
A10	TMB5[4]	B10	TMB5[5]	C10	+1.5	D10	TMB5[6]	E10	TMB5[7]
A11	TMB5[8]	B11	TMB5[9]	C11	GND	D11	TMB5[10]	E11	TMB5[11]
A12	TMB5[12]	B12	TMB5[13]	C12	+1.5	D12	TMB5[14]	E12	TMB5[15]
A13	TMB5[16]	B13	TMB5[17]	C13	GND	D13	TMB5[18]	E13	TMB5[19]
A14	TMB5[20]	B14	TMB5[21]	C14	+1.5	D14	TMB5[22]	E14	TMB5[23]
A15	TMB5[24]	B15	TMB5[25]	C15	GND	D15	TMB5[26]	E15	TMB5[27]
A16	TMB5[28]	B16	TMB5[29]	C16	+1.5	D16	TMB5[30]	E16	TMB5[31]
A17	TMB3[0]	B17	TMB3[1]	C17	GND	D17	TMB3[2]	E17	TMB3[3]
A18	TMB3[4]	B18	TMB3[5]	C18	+1.5	D18	TMB3[6]	E18	TMB3[7]
A19	TMB3[8]	B19	TMB3[9]	C19	GND	D19	TMB3[10]	E19	TMB3[11]
A20	TMB3[12]	B20	TMB3[13]	C20	+1.5	D20	TMB3[14]	E20	TMB3[15]
A21	TMB3[16]	B21	TMB3[17]	C21	GND	D21	TMB3[18]	E21	TMB3[19]
A22	TMB3[20]	B22	TMB3[21]	C22	+1.5	D22	TMB3[22]	E22	TMB3[23]
A23	TMB3[24]	B23	TMB3[25]	C23	GND	D23	TMB3[26]	E23	TMB3[27]
A24	TMB3[28]	B24	TMB3[29]	C24	+1.5	D24	TMB3[30]	E24	TMB3[31]
A25	Winner_1	B25	Winner_3	C25	GND	D25	Winner_5	E25	Winner_7

Table 7

## Pin assignment of the P4 backplane connector (bottom)

Pin	Signal	Pin	Signal	Pin	Signal	Pin	Signal	Pin	Signal
A1	TMB7[0]	B1	TMB7[1]	C1	GND	D1	TMB7[2]	E1	TMB7[3]
A2	TMB7[4]	B2	TMB7[5]	C2	+1.5	D2	TMB7[6]	E2	TMB7[7]
A3	TMB7[8]	B3	TMB7[9]	C3	GND	D3	TMB7[10]	E3	TMB7[11]
A4	TMB7[12]	B4	TMB7[13]	C4	+1.5	D4	TMB7[14]	E4	TMB7[15]
A5	TMB7[16]	B5	TMB7[17]	C5	GND	D5	TMB7[18]	E5	TMB7[19]
A6	TMB7[20]	B6	TMB7[21]	C6	+1.5	D6	TMB7[22]	E6	TMB7[23]
A7	TMB7[24]	B7	TMB7[25]	C7	GND	D7	TMB7[26]	E7	TMB7[27]
A8	TMB7[28]	B8	TMB7[29]	C8	+1.5	D8	TMB7[30]	E8	TMB7[31]
A9	TMB1[0]	B9	TMB1[1]	C9	GND	D9	TMB1[2]	E9	TMB1[3]
A10	TMB1[4]	B10	TMB1[5]	C10	+1.5	D10	TMB1[6]	E10	TMB1[7]

A11	TMB1[8]	B11	TMB1[9]	C11	GND	D11	TMB1[10]	E11	TMB1[11]
A12	TMB1[12]	B12	TMB1[13]	C12	+1.5	D12	TMB1[14]	E12	TMB1[15]
A13	TMB1[16]	B13	TMB1[17]	C13	GND	D13	TMB1[18]	E13	TMB1[19]
A14	TMB1[20]	B14	TMB1[21]	C14	+1.5	D14	TMB1[22]	E14	TMB1[23]
A15	TMB1[24]	B15	TMB1[25]	C15	GND	D15	TMB1[26]	E15	TMB1[27]
A16	TMB1[28]	B16	TMB1[29]	C16	+1.5	D16	TMB1[30]	E16	TMB1[31]
A17	TMB9[0]	B17	TMB9[1]	C17	GND	D17	TMB9[2]	E17	TMB9[3]
A18	TMB9[4]	B18	TMB9[5]	C18	+1.5	D18	TMB9[6]	E18	TMB9[7]
A19	TMB9[8]	B19	TMB9[9]	C19	GND	D19	TMB9[10]	E19	TMB9[11]
A20	TMB9[12]	B20	TMB9[13]	C20	+1.5	D20	TMB9[14]	E20	TMB9[15]
A21	TMB9[16]	B21	TMB9[17]	C21	GND	D21	TMB9[18]	E21	TMB9[19]
A22	TMB9[20]	B22	TMB9[21]	C22	+1.5	D22	TMB9[22]	E22	TMB9[23]
A23	TMB9[24]	B23	TMB9[25]	C23	GND	D23	TMB9[26]	E23	TMB9[27]
A24	TMB9[28]	B24	TMB9[29]	C24	+1.5	D24	TMB9[30]	E24	TMB9[31]
A25	Winner_9	B25		C25	GND	D25		E25	

The BC0 signal that is transmitted to the SP, is a logical OR of 18 BC0 signals from all the TMB[9:1]; it propagates through the MPC2004 independently from the results of sorting.

### 3. “Transparent” Mode of Operation

In this mode the MPC2004 may transmit any (out of 18) incoming LCT to any (out of 3) optical link without sorting, if these LCTs are not masked out by CSR7 and CSR8. The CSR4 (see Section 6.5) defines the mode of operation and the sources for optical links in “transparent” mode. When CSR4[0]=0, the MPC2004 is in “sorter” mode. This is default state after power cycling. When CSR4[0]=1, the MPC2004 is in “transparent” mode. Then the CSR4[15..1] bits specify the sources of data for optical links (see Tables 16-18). Muon\_1 and Muon\_2 correspond to LCT0 and LCT1 respectively from TMB1 on slot 2 in the peripheral crate (or from FIFO\_A1[15..0] and FIFO\_A1[31..16] respectively). Muon\_3 and Muon\_4 correspond to LCT0 and LCT1 respectively from TMB2 on slot 4 in the peripheral crate (or from FIFO\_A2[15..0] and FIFO\_A2[31..16] respectively) and so on. The LCTs with “Quality”=0 are not cancelled in the “transparent” mode and will be sent to SP.

In a “transparent” mode the MPC2004 generates winner bits to those TMB’s, that were selected by CSR4[15..1] if “valid pattern flag” of the selected muon is “1”. The order of “winner” bits is the same in both modes: if LCT0 was selected, the “winner” bit is transmitted in the first 80Mhz frame. If LCT1 was selected, the “winner” bit is transmitted in the second 80Mhz frame. The internal latency of the MPC processing is the same in both modes.

In a “sorter” mode the “vpf” bit from the first best selected muon acts as a “write enable” signal for all FIFO\_B buffers. This assures that all three FIFO\_B buffers will contain an equal number of words. But in “transparent” mode the “vpf” bit of every selected by CSR4[15..1] bits pattern acts as a “write enable” for its own FIFO\_B buffer. So the number of words in FIFO\_B buffers may be different.

#### 4. Interface to Sector Processor

The three best patterns, or “muons” (or two in case of Station 1) selected by sorting unit are sent at 80Mhz from the processing FPGA to three 16-bit TLK2501 serializers, one pattern per serializer. The serializer performs a parallel-to-serial data conversion with 8B/10B decoding. A serialized data is sent to Finisar FTRJ-8519-1-2.5 [7] small form factor (SFF) optical transmitters and further over ~100 m optical cables to SP located in the Track Finder crate in the counting room.

The TLK2501 transmitter latches 16-bit parallel data at a reference clock rate and internally encodes it using 8B/10B format. The resulting 20-bit word is transmitted differentially at 20 times the reference clock frequency. The receiver section on a SP board performs a serial-to-parallel conversion on the input data, synchronizes the resulting 20-bit wide parallel word to the extracted reference clock and applies the 8B/10B decoding. The device has a built-in 8-bit pseudo-random bit stream generator and some other useful features such as a loss of signal detection circuit and power down mode. Parallel data, control and status pins are 3.3V compatible.

The Finisar FTRJ-8519-1-2.5 2x5 pinned SFF transceivers provides bidirectional communication at data rates up to 2.125Gbps (1.6Gbps simplex mode transmission is required in our case). The laser technology is an 850 nm multimode VCSEL. It allows fiber lengths up to 300 m. The transceiver operates at extended voltages (3.15V to 3.60V) and temperature (-10C to +85C) ranges and dissipates less than 750mW. One advantage of the FTRJ-8519-1-2.5 module over similar optical transceivers available from other vendors is a metal enclosure for lower electromagnetic interference.

As described above, each selected by MPC2004 pattern comprises 32 bit. It is transmitted to SP in two 16-bit frames at 80Mhz. The frame format is shown in Table 8.

Table 8

MPC-to-SP Data Format

Frame 1															
15	14	13	12	11	10	9	8	7	6	5	4	3	2	1	0
Vpf	Quality[3..0]				CLCT Pattern ID[3..0]				Wire Group ID[6..0]						
Frame 2															
15	14	13	12	11	10	9	8	7	6	5	4	3	2	1	0
CSC ID[3..0]				Bc0	Bx0	ER	L/R	CLCT Half-strip Pattern ID[7..0] *							

CLCT Half-Strip Pattern ID is between 0 and 159

CLCT Pattern encodes the number of layers and whether the pattern consists of half-strips or di-strips

Wire Group ID is between 0 and 111 and indicates the position of the pattern within the chamber

L/R – Bend Angle Bit indicates whether the track is heading towards lower or higher strip number

VPF – Valid Pattern Flag indicates a valid LCT that has been found by TMB and being sent in the current clock cycle

ER - Synchronization Error

BX0 – The less significant bits of the Bunch Crossing Counter.

BC0 – Bunch Crossing Zero Flag arriving from the TMB

Upon arrival of the L1Reset command, a 3.2 us (=128 bunch crossings) pulse of negative polarity is generated on TX\_EN pin of all three TLK2501 serializers thus setting them into “IDLE” mode required for the periodical synchronization. Immediately after the rising edge of this pulse the unique 8-bit pattern is sent on all three optical links to SP during four bunch crossings (100 ns). The pattern is sent in both frames and comprises a 2-bit Link\_ID[1..0] (bits 0 and 1) and a 6-bit Board\_ID[5..0] (bits 7..2). The Board\_ID[5..0] is programmable and available from the CSR0. Link\_ID[1..0] is fixed in firmware and equal to “1” for Link1 (“Muon\_1”), “2” for Link2 (“Muon\_2”) and “3” for Link3 (“Muon\_3”). A timing diagram is shown on Fig. 2.

Note that the CSR0[9] (when “0”) unconditionally sets all the serializers into “IDLE” mode. For normal operation it should be set to “1”. The CSR2[0] (when “0”) sets all serializers into normal data transmission mode. If CSR2[0]=1, all serializers are in “IDLE” mode unless there is a valid pattern or BC0 signal from TMB’s.

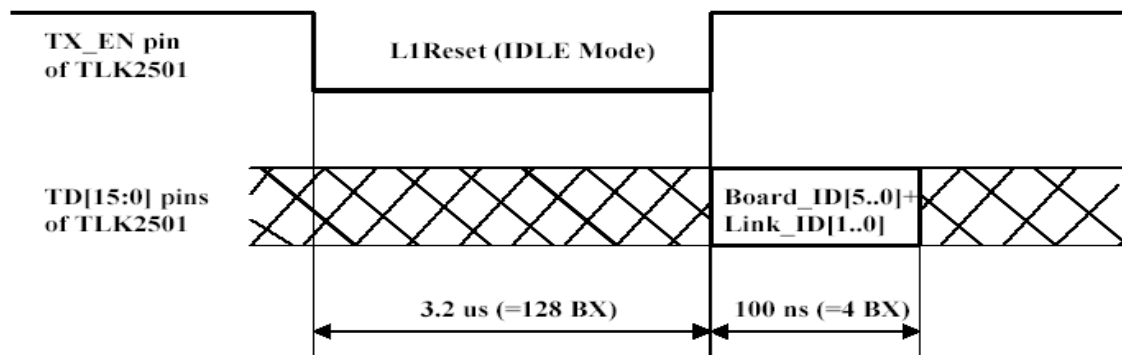

Figure 2. Timing Diagram of the Synchronization Procedure

## 5. VME Interface

The MPC2004 can be accessed in the VME crate using geographical addressing that utilizes the address pins GA<4-0> available on the VME64x backplane. The MPC2004 resides on slot 12 of the peripheral EMU backplane, so its base geographical address is 600000(hex). The board responds to AM codes 39(hex), 3D(hex) and supports A24D16 slave operations. It does not respond to byte-addressing modes, so all valid addresses must be even numbers. Decoded addresses and VME commands are listed in Table 9. Input and Output FIFO buffers and Control and Status Registers (CSR) are described in Sections 6 and 7 respectively.

The main part of the VME interface (data drivers, address latches, address comparators, DACK response logic, CSR0) is implemented in discrete logic. This means that the board is accessible even without mezzanine card that carries the Xilinx FPGA.

Table 9

Address (hex)	Access	Function
600000	Read/Write	CSR0
600002	Write	Hard_Reset command to FPGA



600004	Write	Soft Reset command to FPGA
600006	Write	Reset DLL in the FPGA
600080	Read/Write	FIFO_A1[15..0]. Corresponds to TMB1_LCT1
600082	Read/Write	FIFO_A1[31..16]. Corresponds to TMB1_LCT0
600084	Read/Write	FIFO_A2[15..0]. Corresponds to TMB2_LCT1
600086	Read/Write	FIFO_A2[31..16]. Corresponds to TMB2_LCT0
600088	Read/Write	FIFO_A3[15..0]. Corresponds to TMB3_LCT1
60008A	Read/Write	FIFO_A3[31..16]. Corresponds to TMB3_LCT0
60008C	Read/Write	FIFO_A4[15..0]. Corresponds to TMB4_LCT1
60008E	Read/Write	FIFO_A4[31..16]. Corresponds to TMB4_LCT0
600090	Read/Write	FIFO_A5[15..0]. Corresponds to TMB5_LCT1
600092	Read/Write	FIFO_A5[31..16]. Corresponds to TMB5_LCT0
600094	Read/Write	FIFO_A6[15..0]. Corresponds to TMB6_LCT1
600096	Read/Write	FIFO_A6[31..16]. Corresponds to TMB6_LCT0
600098	Read/Write	FIFO_A7[15..0]. Corresponds to TMB7_LCT1
60009A	Read/Write	FIFO_A7[31..16]. Corresponds to TMB7_LCT0
60009C	Read/Write	FIFO_A8[15..0]. Corresponds to TMB8_LCT1
60009E	Read/Write	FIFO_A8[31..16]. Corresponds to TMB8_LCT0
6000A0	Read/Write	FIFO_A9[15..0]. Corresponds to TMB9_LCT1
6000A2	Read/Write	FIFO_A9[31..16]. Corresponds to TMB9_LCT0
6000A4	Read/Write	FIFO_B1[15..0]. Corresponds to 1 <sup>st</sup> best selected LCT
6000A6	Read/Write	FIFO_B2[15..0]. Corresponds to 2 <sup>nd</sup> best selected LCT
6000A8	Read/Write	FIFO_B3[15..0]. Corresponds to 3 <sup>rd</sup> best selected LCT
6000AA	Read/Write	CSR1 (date of the current firmware version)
6000AC	Read/Write	CSR2 (control)
6000AE	Read	CSR3 (FIFO Status)
6000B0	Read	L1ACC Counter
6000B2	Write	Transmit 511 words of data from all FIFO_A buffers in “Test” mode
6000B4	Write	
6000B6	Write	Send a 3.2 us TxEn “0” pulse to all three TLK2501 transmitters
6000B8	Read/Write	CSR4 (control, “transparent” mode)
6000BA	Read/Write	CSR5 (general purpose register)
6000BC	Read	CSR6 (access to DS2401 serial number)
6000BE		
6000C0	Write	Generate 800 us “Reset pulse” on 1-Wire bus to initialize the serial ID chip (write only)
6000C2	Write	Generate 3 us “Read pulse” on 1-Wire bus to read data from the serial ID chip (write only)
6000C4	Write	Reset CSR6 (write only)
6000C6	Write	Generate “Write-zero” 50 us pulse on 1-Wire bus to send a command to serial ID chip (write only)
6000C8	Write	Generate “Write-one” 12 us pulse on 1-Wire bus to send a command to serial ID chip (write only)
6000CA	Read/Write	CSR7 (enable/disable TMB1..TMB8)
6000CC	Read/Write	CSR8 (enable/disable TMB9)
6000CE		

## 6. FIFO Buffers

Two groups of FIFO Buffers (FIFO\_A and FIFO\_B) are implemented in the main FPGA in order to test the MPC2004 internal functionality and its communications with the Trigger Motherboards and Sector Processor. Both buffers are 511-word deep and available from VME for read and write (Table 8). Since two muon patterns are packed

into FIFO\_A in two frames, each FIFO effectively comprises 255 patterns. Each buffer represents data corresponding to one TMB board, or two muon patterns. FIFO\_A1 corresponds to TMB1, FIFO\_A2 corresponds to TMB2 and so on. Its format is shown in Table 10. In a “Test” mode the test patterns representing 18 muons are sent out simultaneously from all FIFO\_A buffers at 80Mhz upon specific TTC or VME commands (see Tables 2 and 9). They pass through the sorting logic that selects the three best patterns and transmits them to the SP and FIFO\_B buffers. FIFO\_B format is shown in Table 11.

One important feature of all FIFO\_B buffers is that the data from FIFO\_A (“Test” mode) or TMB’s (“Trigger” mode) can be saved in FIFO\_B only if there is at least one valid muon pattern, or pattern with “vpf”=1. Also note that the “quality” of the selected LCT should be non-zero. This allows acquiring into FIFO\_B the data, representing only valid patterns. The “vpf” bit from the first best selected muon acts as a “write enable” signal for all FIFO\_B buffers. This means that if there is just one valid pattern coming after sorting from FIFO\_A or TMB, it will be stored in FIFO\_B1 and “0” will be written into FIFO\_B[2..3]. This mechanism assures that all three FIFO\_B buffers will contain an equal number of words inside. As for VME access, any data can be loaded and read back out of any FIFO\_B buffer independently.

The FULL and EMPTY flags (common to all FIFO\_A and FIFO\_B buffers) are available for read from CSR2. After an asynchronous FIFO reset all these flags are active “1”.

Table 10

FIFO\_A Data Format

FIFO_A Frame 1 (LCT1)															
15	14	13	12	11	10	9	8	7	6	5	4	3	2	1	0
vpf	Quality[3..0]			CLCT Pattern[3..0]				Wire Group ID[6..0]							
FIFO_A Frame 1 (LCT0)															
31	30	29	28	27	26	25	24	23	22	21	20	19	18	17	16
vpf	Quality[3..0]			CLCT Pattern[3..0]				Wire Group ID[6..0]							
FIFO_A Frame 2 (LCT1)															
15	14	13	12	11	10	9	8	7	6	5	4	3	2	1	0
CSC_ID[3..0]				Bc0	Bx0	ER	L/R	CLCT Half-strip ID[7..0]							
FIFO_A Frame 2 (LCT0)															
31	30	29	28	27	26	25	24	23	22	21	20	19	18	17	16
CSC_ID[3..0]				Bc0	Bx0	ER	L/R	CLCT Half-strip ID[7..0]							

Table 11

FIFO\_B Data Format

FIFO_B Frame 1															
15	14	13	12	11	10	9	8	7	6	5	4	3	2	1	0
Vpf	Quality[3..0]			CLCT Pattern ID[3..0]				Wire Group ID[6..0]							
FIFO_B Frame 2															
15	14	13	12	11	10	9	8	7	6	5	4	3	2	1	0
CSC_ID[3..0]				Bc0	Bx0	ER	L/R	CLCT Half-strip Pattern ID[7..0]							

## 7. Control and Status Registers

The 16-bit CSR0 is implemented in discrete logic and available for write and read over VME even if the mezzanine card is not installed. Bit assignment is shown in Table 12. The other registers are implemented inside the FPGA (see Tables 13-19).

### 7.1. CSR0 (600000h, discrete logic)

Table 12

Bit and access	Function
0 (R/W)	FPGA Mode (Trigger mode if "0", Test mode (FIFO A is a source of data) if "1")
1 (R/W)	Board ID[0]
2 (R/W)	Board ID[1]
3 (R/W)	Board ID[2]
4 (R/W)	Board ID[3]
5 (R/W)	TDI (JTAG signal for FPGA/EPROM access)
6 (R/W)	TMS (JTAG signal for FPGA/EPROM access)
7 (R/W)	TCK (JTAG signal for FPGA/EPROM access)
8 (R)	TDO (JTAG signal for FPGA/EPROM access)
9 (R/W)	TxEn signal for TLK2501 transmitters ("1" for normal data transfer mode)
10 (R/W)	Board ID[4]
11 (R/W)	Board ID[5]
12 (R)	FPGA Configuration Done (read only, active "1")
13 (R/W)	If "0", the input FPGA clock should be adjusted with the CSR2[15..8] If "1", the input FPGA clock is adjusted automatically in the middle of the "safe window"
14 (R/W)	Enable TLK2501 serializers when "1". If "0", all TLK2501 are in power-down mode
15 (R/W)	PRBSEN (Enable PRBS test mode for all TLK2501 serializers when "1")

### 7.2. CSR1 (6000AAh, FPGA, contains the date of the firmware version)

Table 13

Bit and access	Function
0 (R)	Day, LSB
1 (R)	Day
2 (R)	Day
3 (R)	Day
4 (R)	Day, MSB
5 (R)	Month, LSB
6 (R)	Month
7 (R)	Month
8 (R)	Month, MSB
9 (R)	Year, LSB (*)
10 (R)	Year (*)
11 (R)	Year, MSB (*)
12 (R)	"0"
13 (R)	"0"
14 (R)	"0"
15 (R)	"0"

(\*) The code at CSR1<11..9> should be added to 2000 to get an actual year. For example, CSR1=1252(dec) corresponds to July 4, 2002.

### 7.3. CSR2 (6000ACh, FPGA, control register, by default set to “0”)

Table 14

Bit and access	Function
0 (R/W)	When “0”, all TLK2501 transmitters are in “Normal data character” mode. When “1”, all TLK2501 are in IDLE mode, unless there is a Valid Pattern or BC0 from TMB
1 (R/W)	Not used
2 (R/W)	Not used
3 (R/W)	Not used
4 (R/W)	Not used
5 (R/W)	Not used
6 (R/W)	Not used
7 (R/W)	Not used
8 (R/W)	Delay of the 40Mhz input clock for the FPGA, LSB (*)
9 (R/W)	Delay of the 40Mhz input clock for the FPGA (*)
10 (R/W)	Delay of the 40Mhz input clock for the FPGA (*)
11 (R/W)	Delay of the 40Mhz input clock for the FPGA (*)
12 (R/W)	Delay of the 40Mhz input clock for the FPGA (*)
13 (R/W)	Delay of the 40Mhz input clock for the FPGA (*)
14 (R/W)	Delay of the 40Mhz input clock for the FPGA (*)
15 (R/W)	Delay of the 40Mhz input clock for the FPGA, MSB (*)

(\*) - 1 step = 0.25 ns. Implemented using 3D7408-0.25 programmable delay chip from Data Delay Devices

### 7.4. CSR3 (6000AEh, FPGA, FIFO status register)

Table 15

Bit and access	Function
0 (R)	FIFO_A FULL. Active “1” if at least one out of nine FIFO_A buffers is full
1 (R)	FIFO_A EMPTY. Active “1” if ALL nine FIFO_A buffers are empty. Also “1” after reset
2 (R)	FIFO_B FULL. Active “1” if at least one out of three FIFO_B buffers is full
3 (R)	FIFO_B EMPTY. Active “1” if ALL three FIFO_B buffers are empty. Also “1” after reset
4 (R)	“0”
5 (R)	“0”
6 (R)	“0”
7 (R)	“0”
8 (R)	“0”
9 (R)	“0”
10 (R)	“0”
11 (R)	“0”
12 (R)	“0”
13 (R)	“0”
14 (R)	“0”
15 (R)	“0”

**7.5. CSR4 (6000B8h, FPGA, controls the “transparent” mode, by default set to “0”)**

Table 16

Bits in CSR4															Source of data to optolink 1 (1st best) and FIFO_B1	
15	14	13	12	11	10	9	8	7	6	5	4	3	2	1	0	
x	x	x	x	x	x	x	x	x	x	x	x	x	x	x	0	“sorter” mode
0	0	0	0	0	0	0	0	0	0	0	0	0	0	0	1	All sources disabled
x	x	x	x	x	x	x	x	x	x	0	0	0	0	1	1	TMB1_LCT1
x	x	x	x	x	x	x	x	x	x	0	0	0	1	0	1	TMB1_LCT0
x	x	x	x	x	x	x	x	x	x	0	0	0	1	1	1	TMB2_LCT1
x	x	x	x	x	x	x	x	x	x	0	0	1	0	0	1	TMB2_LCT0
x	x	x	x	x	x	x	x	x	x	0	0	1	0	1	1	TMB3_LCT1
x	x	x	x	x	x	x	x	x	x	0	0	1	1	0	1	TMB3_LCT0
x	x	x	x	x	x	x	x	x	x	0	0	1	1	1	1	TMB4_LCT1
x	x	x	x	x	x	x	x	x	x	0	1	0	0	0	1	TMB4_LCT0
x	x	x	x	x	x	x	x	x	x	0	1	0	0	1	1	TMB5_LCT1
x	x	x	x	x	x	x	x	x	x	0	1	0	1	0	1	TMB5_LCT0
x	x	x	x	x	x	x	x	x	x	0	1	0	1	1	1	TMB6_LCT1
x	x	x	x	x	x	x	x	x	x	0	1	1	0	0	1	TMB6_LCT0
x	x	x	x	x	x	x	x	x	x	0	1	1	0	1	1	TMB7_LCT1
x	x	x	x	x	x	x	x	x	x	0	1	1	1	0	1	TMB7_LCT0
x	x	x	x	x	x	x	x	x	x	0	1	1	1	1	1	TMB8_LCT1
x	x	x	x	x	x	x	x	x	x	1	0	0	0	0	1	TMB8_LCT0
x	x	x	x	x	x	x	x	x	x	1	0	0	0	1	1	TMB9_LCT1
x	x	x	x	x	x	x	x	x	x	1	0	0	1	0	1	TMB9_LCT0

Table 17

Bits in CSR4															Source of data to optolink 2 (2nd best) and FIFO_B2	
15	14	13	12	11	10	9	8	7	6	5	4	3	2	1	0	
x	x	x	x	x	x	x	x	x	x	x	x	x	x	x	0	“sorter” mode
0	0	0	0	0	0	0	0	0	0	0	0	0	0	0	1	All sources disabled
x	x	x	x	x	0	0	0	0	1	x	x	x	x	x	1	TMB1_LCT1
x	x	x	x	x	0	0	0	1	0	x	x	x	x	x	1	TMB1_LCT0
x	x	x	x	x	0	0	0	1	1	x	x	x	x	x	1	TMB2_LCT1
x	x	x	x	x	0	0	1	0	0	x	x	x	x	x	1	TMB2_LCT0
x	x	x	x	x	0	0	1	0	1	x	x	x	x	x	1	TMB3_LCT1
x	x	x	x	x	0	0	1	1	0	x	x	x	x	x	1	TMB3_LCT0
x	x	x	x	x	0	0	1	1	1	x	x	x	x	x	1	TMB4_LCT1
x	x	x	x	x	0	1	0	0	0	x	x	x	x	x	1	TMB4_LCT0
x	x	x	x	x	0	1	0	0	1	x	x	x	x	x	1	TMB5_LCT1
x	x	x	x	x	0	1	0	1	0	x	x	x	x	x	1	TMB5_LCT0
x	x	x	x	x	0	1	0	1	1	x	x	x	x	x	1	TMB6_LCT1
x	x	x	x	x	0	1	1	0	0	x	x	x	x	x	1	TMB6_LCT0
x	x	x	x	x	0	1	1	0	1	x	x	x	x	x	1	TMB7_LCT1
x	x	x	x	x	0	1	1	1	0	x	x	x	x	x	1	TMB7_LCT0
x	x	x	x	x	0	1	1	1	1	x	x	x	x	x	1	TMB8_LCT1
x	x	x	x	x	1	0	0	0	0	x	x	x	x	x	1	TMB8_LCT0
x	x	x	x	x	1	0	0	0	1	x	x	x	x	x	1	TMB9_LCT1
x	x	x	x	x	1	0	0	1	0	x	x	x	x	x	1	TMB9_LCT0

Table 18

Bits in CSR4															Source of data to optolink 3 (3rd best) and FIFO_B3		
15	14	13	12	11	10	9	8	7	6	5	4	3	2	1	0		
x	x	x	x	x	x	x	x	x	x	x	x	x	x	x	x	0	“sorter” mode
0	0	0	0	0	0	0	0	0	0	0	0	0	0	0	1		All sources disabled
0	0	0	0	1	x	x	x	x	x	x	x	x	x	x	x	1	TMB1_LCT1
0	0	0	1	0	x	x	x	x	x	x	x	x	x	x	x	1	TMB1_LCT0
0	0	0	1	1	x	x	x	x	x	x	x	x	x	x	x	1	TMB2_LCT1
0	0	1	0	0	x	x	x	x	x	x	x	x	x	x	x	1	TMB2_LCT0
0	0	1	0	1	x	x	x	x	x	x	x	x	x	x	x	1	TMB3_LCT1
0	0	1	1	0	x	x	x	x	x	x	x	x	x	x	x	1	TMB3_LCT0
0	0	1	1	1	x	x	x	x	x	x	x	x	x	x	x	1	TMB4_LCT1
0	1	0	0	0	x	x	x	x	x	x	x	x	x	x	x	1	TMB4_LCT0
0	1	0	0	1	x	x	x	x	x	x	x	x	x	x	x	1	TMB5_LCT1
0	1	0	1	0	x	x	x	x	x	x	x	x	x	x	x	1	TMB5_LCT0
0	1	0	1	1	x	x	x	x	x	x	x	x	x	x	x	1	TMB6_LCT1
0	1	1	0	0	x	x	x	x	x	x	x	x	x	x	x	1	TMB6_LCT0
0	1	1	0	1	x	x	x	x	x	x	x	x	x	x	x	1	TMB7_LCT1
0	1	1	1	0	x	x	x	x	x	x	x	x	x	x	x	1	TMB7_LCT0
0	1	1	1	1	x	x	x	x	x	x	x	x	x	x	x	1	TMB8_LCT1
1	0	0	0	0	x	x	x	x	x	x	x	x	x	x	x	1	TMB8_LCT0
1	0	0	0	1	x	x	x	x	x	x	x	x	x	x	x	1	TMB9_LCT1
1	0	0	1	0	x	x	x	x	x	x	x	x	x	x	x	1	TMB9_LCT0

### 7.6. CSR6 (6000BCh, FPGA, access to DS2401 serial number)

Table 19

Bit	Access	Function
0	R	« 0 » indicates the « Presence pulse » from serial ID chip after the « Reset pulse »
1	R	Data bit from serial ID chip DS2401
2	R	Status of the initialization. When « 1 » after the « Reset pulse », the CSR6[0] is valid
3	R	Status of the read cycle. When « 1 » after the « Read pulse », the CSR6[1] is valid
4	R	Status of the command cycle. When « 1 » after the « Write-one » or « Write-zero » command, the next command can be sent
5	R	« 0 »
6	R	« 0 »
7	R	« 0 »
8	R	« 0 »
9	R	« 0 »
10	R	« 0 »
11	R	« 0 »
12	R	« 0 »
13	R	« 0 »
14	R	« 0 »
15	R	« 0 »

### 7.7. CSR7 (6000CAh, FPGA, enable/disable LCT's from TMB[8:1], by default set to “0”)

Table 20

Bit	Access	Function
0	R/W	Enable (if « 0 ») or Disable (if « 1 ») LCT1 from TMB1, enabled by default

1	R/W	Enable (if « 0 ») or Disable (if « 1 ») LCT0 from TMB1, enabled by default
2	R/W	Enable (if « 0 ») or Disable (if « 1 ») LCT1 from TMB2, enabled by default
3	R/W	Enable (if « 0 ») or Disable (if « 1 ») LCT0 from TMB2, enabled by default
4	R/W	Enable (if « 0 ») or Disable (if « 1 ») LCT1 from TMB3, enabled by default
5	R/W	Enable (if « 0 ») or Disable (if « 1 ») LCT0 from TMB3, enabled by default
6	R/W	Enable (if « 0 ») or Disable (if « 1 ») LCT1 from TMB4, enabled by default
7	R/W	Enable (if « 0 ») or Disable (if « 1 ») LCT0 from TMB4, enabled by default
8	R/W	Enable (if « 0 ») or Disable (if « 1 ») LCT1 from TMB5, enabled by default
9	R/W	Enable (if « 0 ») or Disable (if « 1 ») LCT0 from TMB5, enabled by default
10	R/W	Enable (if « 0 ») or Disable (if « 1 ») LCT1 from TMB6, enabled by default
11	R/W	Enable (if « 0 ») or Disable (if « 1 ») LCT0 from TMB6, enabled by default
12	R/W	Enable (if « 0 ») or Disable (if « 1 ») LCT1 from TMB7, enabled by default
13	R/W	Enable (if « 0 ») or Disable (if « 1 ») LCT0 from TMB7, enabled by default
14	R/W	Enable (if « 0 ») or Disable (if « 1 ») LCT1 from TMB8, enabled by default
15	R/W	Enable (if « 0 ») or Disable (if « 1 ») LCT0 from TMB8, enabled by default

### 7.8. CSR8 (6000CCh, FPGA, enable/disable LCT's from TMB9, by default set to "0")

Table 21

Bit	Access	Function
0	R/W	Enable (if « 0 ») or Disable (if « 1 ») LCT1 from TMB9, enabled by default
1	R/W	Enable (if « 0 ») or Disable (if « 1 ») LCT0 from TMB9, enabled by default
2	R/W	-
3	R/W	-
4	R/W	-
5	R/W	-
6	R/W	-
7	R/W	-
8	R/W	-
9	R/W	-
10	R/W	-
11	R/W	-
12	R/W	-
13	R/W	-
14	R/W	-
15	R/W	-

## 8. Mezzanine Board and JTAG Access to FPGA and EPROM

A mezzanine card comprises one Xilinx XCV600E-8FG680C and one XC18V04 EPROM which are accessible over JTAG bus (FPGA is the first device in a JTAG chain and the EPROM is the second one). They can be accessed from Xilinx Parallel Cable IV (14-pin connector is located on the front panel) or from CSR0[8..5]. Switch S8-1 defines which of these two options is activated (Xilinx cable if S8-1 is "on" and CSR0[8..5] if S8-1 is "off")

Two clock signals for the FPGA are provided from the main MPC board. Either CCB clock obtained from the backplane or an internal 40.08Mhz clock from on-board oscillator (80.16Mhz divided by two) can be used. One of these clocks can be delayed on

the main board using 3D7408-0.25 delay line [8] from Data Delay Devices. The delay value can be set using CSR2[15..8].

## 9. Serial Number Access

There is a Silicon Serial Number DS2401 [9] chip that consists of a factory-lasered, 64-bit ROM that includes a unique 48-bit serial number, an 8-bit CRC, and an 8-bit Family Code (01h). Data is transferred serially via the 1-Wire protocol, read and write least significant bit first. The protocol details and timing diagrams are given in [9]. An access to serial number chip consists of three phases: Initialization, ROM Function Command, and Read Data.

The Initialization sequence consists of a “Reset pulse” transmitted by the master followed by a “Presence pulse” transmitted by the DS2401. The “Presence pulse” lets the bus master know that the DS2401 is on the bus and ready to operate. For the Initialization, the “Reset pulse” should be sent, then CSR6[2] should be checked, and, when the CSR6[2]=1, the CSR6[0] should be checked. If CSR6[0]=0 at this moment, that means that the “Presence pulse” was sent and the next step can be performed.

The ROM Function Command phase consists of sending a Read ROM command [33h] or [0Fh] to DS2401. The first bit (“Write-one”) should be sent, then CSR6[4] scanned, and, when CSR6[4]=1, the next bit of command should be sent. Since all commands are 8-bit long, eight write operations are necessary.

The Read Data phase consists of 64 read cycles. Each cycle starts with sending a “Read pulse”, then CSR6[3] is scanned, and, when CSR6[3]=1, the valid data bit should be received from CSR6[1]. Note the first data bit should be “1” and the next seven bits should be “0” (they represent the Family Code 01h). Bits 49-56 are also “0” and bits 57-64 represent the CRC code.

## 10. Fuses

Fuse F10 monitors +5V power from VME J1 backplane. Fuse F7 monitors +1.8V power for the mezzanine FPGA. Fuse F9 monitors +2.5V power for TLK2501 transceivers. All these fuses are required at any time.

Fuse F8 monitors +3.3V power from J1 VME64x backplane while fuse F11 monitors +3.3V from on-board voltage regulator U65. Only one (either F8 or F11) fuse should be installed at a time. For VME64x backplane the F8 is required.

Fuses F1-F4 monitor reference voltages for GTLP transceivers (+1.0V) and GTLP terminators (+1.5V). Fuses F1 and F3 monitor these powers from custom backplane while F2 and F4 monitor powers from on-board voltage regulator U64. Only one pair (F1+F3 or F2+F4) should be installed at a time. If custom EMU peripheral backplane is being used, the pair of F1+F3 is required.



## 11. Switches

Switch S1 is needed to select the source of the master clock. If S1-1 is “on”, the source is 40.08 clock from the CCB. If S1-2 is “on”, the source is an on-board quartz oscillator (80.157 Mhz divided by 2). The default option is when S1-1 is “on”.

Switch S2 provides either master (if S2-1 is “on”) or delayed master (if S2-2 is “on”) clocks to the mezzanine FPGA. The source of this master clock is defined by S1. The delay value can be set by CSR2[15..8] with the step of 0.25 ns.

Switch S5 can be used to chose a permanent delay value for the 3D7408-0.25 delay element instead of programmable from CSR2[15..8]. Should be used for debugging purposes only.

Switch S8 is needed to chose the source of JTAG access to mezzanine FPGA. When S8-1 is “on”, the source is a JTAG cable connected over front panel. When S8-1 is “off” the CSR0[5..8] are used for JTAG access. S8-2 is needed to disable (when “on”) an on-board 80.16Mhz clock oscillator (required only for debugging purposes).

Switch S10 is used to define the A[15..8] bits of the base address. S10-1 corresponds to A8, S10-2 corresponds to A9 and so on. When any switch is set “on”, the respective bit is set to “0”. When any switch is “off”, the respective bit is set to “1”. The default option is when all S10 switches are set “on”.

S11 should be used only for debugging purposes. It allows to select the geographical addresses GA[4..0] when the VME64x backplane is not available.

S12 chooses the source of 80Mhz clock for all three TLK2501 serializers. If S12-1 is “on”, the source is an on-board oscillator. If S12-2 is “on”, the source is 80Mhz clock delivered by CCB board over backplane. If S12-3 is “on”, the source is on-board AV9170 clock generator. If S12-4 is “on”, the source is 80Mhz clock generated by the FPGA. Only one switch should be “on” at a time. It is recommended to use a direct CCB clock (S12-2 is “on”).

S13 chooses the options for 40Mhz clock generation for the FPGA. If S13-1 is “on”, the 40Mhz clock arrives from the source defined by S2. If S13-2 is “on”, the 40Mhz clock arrives from the AV9170 clock generator. Only one switch (S13-1 or S13-2) should be “on”. It is recommended to set S13-1 “on”. S13-3 and S13-4 provide a feedback input for the AV9170 clock generator. If S13-3 is “on”, the feedback input is a direct 40Mhz output from AV9170. If S13-4 is “on”, the feedback a 40Mhz output from AV9170 delayed by a clock buffer for ~2 ns. Only one switch (S13-3 or S13-4) should be “on” at a time. It is recommended to set S13-4 “on”.

## 12. Front Panel

There are on the front panel:

- Three optical modules for communication with the Sector Processor
- Three red LEDs “MUON[1..3]” (D1-D3, with one-shots) that indicate “vpf” bits of three output patterns passing to SP and FIFO\_B
- Green LED “DONE” (D4) indicates that the FPGA configuration and initialization were done properly and the DLL is locked
- Yellow LED “TEST” (D5) indicates the “Test” mode, when FIFO\_A is a data source for the sorter logic
- Red LED “HRES” (D6, with one-shot) indicates the Hard\_Reset command (either from CCB or from write to VME address 600002h)
- Yellow LED “TCK” (D7) indicates active TCK signal from CSR0[7]
- Yellow LED “DACK” (D9, with one-shot) indicates an access to MPC over VME
- Red LED “SRES” (D8, with one-shot) indicates the Soft\_Reset command (either from VME SYSRESET line or from write to VME address 600004h)
- Green LEDs “+5V” (D18), “+3.3V” (D19), “+2.5V” (D20), “+1.8V” (D21), “+1.5VA” (D22) and “+1.5VB” (D23) indicate active on-board power supplies
- Red LED “IDLE” (D10, with one-shot) indicates that all three TLK2501 serializers are switched into IDLE mode
- Red LED “RNTS” (Run Test) (D11, with one shot) indicates that data transmission from FIFO\_A buffer was initiated upon VME or CCB command
- Red LED “L1RS” (L1 Reset) (D12, with one-shot) indicates that L1 Reset command had been decoded
- Red LED “FAEM” (FIFO\_A Empty) (D13) indicates that all nine FIFO\_A buffers are empty
- Red LED “FBEM” (FIFO\_B Empty) (D14) indicates that all three FIFO\_B buffers are empty
- Red LED “FAFL” (FIFO\_A Full) (D15) indicated that at least one out of nine FIFO\_A buffers is full
- Red LED “FBFL” (FIFO\_B Full) (D16) indicated that at least one out of three FIFO\_B buffers is full
- Red LED “CLK40” (D17) indicates that the 40Mhz clock is valid (when blinking at ~5 Hz)

## References

- [1] The CSC Track Finder. <http://www.phys.ufl.edu/~acosta/cms/trigger.html>
- [2] <http://www-collider.physics.ucla.edu/cms/trigger/>
- [3] CMS CSC DAQ Motherboard. <http://www.physics.ohio-state.edu/~cms/dmb/est/>
- [4] <http://bonner-ntserver.rice.edu/cms/projects.html#ccb>
- [5] A.Madorsky. Pin assignment for the boards in the peripheral crate. Available at: <http://www.phys.ufl.edu/~madorsky/backplane/PinAssignment.doc>
- [6] <http://www-s.ti.com/sc/psheets/slls427b.slls427b.pdf>

[7] <http://www.finisar.com/pdf/2x5sff-2gig.pdf>

[8] <http://www.datadelay.com/>

[9]. DS2401 Silicon Serial Number Specification. Available at <http://pdfserv.maxim-ic.com/en/ds/DS2401.pdf>

## History

**03/17/2005.** Initial release.

**05/16/2005.** Minor changes in text.

**10/20/2005.** Additions to Section 2. Bit CSR0[13] was specified (Table 12).

**11/24/2005.** Addition to Section 2 (Transparent BC0).

**03/17/2006.** Major changes in CSR0 (Section 7.1). Board\_ID[5..0] bits added. Section 4.1 was removed.

**04/26/2006.** Link\_ID[1..0] was added (Section 4).

**10/26/2006.** CSR7 and CSR8 were added to allow mask out any LCT from any TMB (or FIFO\_A buffer). Corresponding firmware files are mpc2004\_102606.mcs and mpc2004\_102606.svf.

**02/12/2007.** Signal names were changed in Tables 4-7.

**10/08/2008.** Change in sorting scheme (page 3): if two LCTs from the same TMB are selected and both have the same “quality” value, then the LCT0 will have the precedence over LCT1 (and opposite in all the previous version of the firmware). Tables 9, 10, 16, 17, 18, 20, 21 have been changed accordingly.